

COMPACT WHEEL LOADER

takeuchi
From World First to World Leader

TW65 SERIES 2



Product Features & Specifications

ENGINE

- U.S. EPA Final Tier 4 Emission
- DOC Exhaust After Treatment
- Turbocharged
- Water Cooled
- Dual Element Air Cleaner with Restriction Indicator
- High Capacity Radiator

ELECTRICAL

- Multi-Informational Display
- 12 volt System with 95 amp Alternator
- Work Lights: Front and Rear
- Driving Lights and Turn Signals
- Directional Lights: Fwd / Rev
- Engine Preheat
- Back-up Alarm

DRIVE TRAIN

- Hydrostatic Drive with 100% Inching Pedal
- 100% Locking Differentials: Front and Rear
- Outboard Planetary Drives
- Two-Speed Travel
- Spring Applied Parking Brake
- Multi-Wet Disc Brake
- Construction Tire Assembly (optional)
- Floatation Tire Assembly (optional)
- High Speed Road Gear with Ride Control (24.8 mph) (optional)

OPERATOR'S STATION

- Enclosed Cab with Air Conditioning, Heat, Front and Rear Wipers, Front and Rear Washer and Rear Window Defrost
- Elevated Operator's Station
- ROPS / FOPS Protection
- Deluxe Air Suspension Seat with Arm Rests
- Multi-Functional Joystick for Machine Direction Forward and Reverse
- Auxiliary Circuit Thumb Switch and Loader Controls
- Large Steps and Grab Handles
- 2" Retractable Seat Belt
- 3" Retractable Seat Belt (optional)

HYDRAULIC & WORKING EQUIPMENT

- Pilot Control
- Proportional Slide Switch Located in Loader Joystick for Auxiliary Hydraulic Circuit
- Auxiliary Hydraulic Lines Plumbed to End of Loader Arms
- Auxiliary Hydraulic Detent
- Hydraulic Oil Level Sight Gauge
- High Capacity Hydraulic Oil Cooler
- Z-Bar Linkage
- Bucket Float Function
- Mechanical Bucket Positioning
- Heavy Duty Hydraulic Bucket Quick Coupler
- Heavy Duty Self Aligning Loader Bushings with Oversized Pins
- High Flow Auxiliary Hydraulics (26.0 gpm) (optional)
- Combo Hitch to Universal SSL Adaptor (optional)
- Flat Face Hydraulic Coupler Kit (optional)



Operator's Station



Outboard Planetary Drives

TOUGH, POWERFUL, RELIABLE



Monitor Display



Two-Speed Travel



Spacious Cabin



Multi-Function Joystick

The TW65 Series 2 features a compact design that is ideal for maneuvering in tight spaces with minimal damage to lawns and other sensitive surfaces. Delivering 73 horsepower, the TW65 Series 2 is equipped with a powerful, turbocharged Deutz engine that is EPA Final Tier 4 compliant. The loader has excellent reach, dump height, and lifting capabilities making it suitable for a wide variety of applications, and the

standard hydraulic coupler simplifies attachment exchanges. The operator's station is elevated and unobstructed for greater visibility and job site awareness. Excellent power and precise control result in increased productivity, and with lower operational and maintenance costs the TW65 Series 2 is a great alternative to the skid steer loader.



Large lockable rear service hood provide outstanding service and maintenance access.

OPERATING PERFORMANCE

Operating Weight - Cab	11,354 lb	(5,150 kg)
Tipping Load, Straight	9,171 lb	(4,160 kg)
Tipping Load, Full Turn	8,100 lb	(3,674 kg)
Operating Capacity, SAE J818*	4,050 lb	(1,837 kg)
Bucket Breakout Force	11,600 lb	(5,262 kg)
Lift Arm Breakout Force	10,319 lb	(4,680 kg)
Traction Force	9,217 lb	(4,180 kg)
Travel Speed - Low Range	4.0 mph	(6.5 km/hr)
High Range	12.4 mph	(20.0 km/hr)
Optional High Speed Travel	24.8 mph	(40.0 km/hr)

* Rate Operating Capacity (ROC) for wheel loaders is rated with a bucket according to SAE J818 at no more than 50% of the full turn tipping load.

HYDRAULIC SYSTEM

Auxiliary Flow - Primary Circuit	16.4 gpm	(62.0 Lpm)
Auxiliary Flow - Optional High Flow	26.0 gpm	(98.0 Lpm)
Hydraulic System Pressure	3,335 psi	(23.0 MPa)

ENGINE

Make/Model	Deutz / TD 2.9L Turbo	
Engine Displacement	176 cu in	(2.9 L)
Horsepower @ 2,200 rpm	73 hp	(54.0 kW)
Maximum Torque @ 1,800 rpm	192 ft-lb	(260.0 Nm)

FLUID CAPACITIES

Engine Lubrication	2.11 qt	(8.0 L)
Fuel Tank Capacity	26.4 gal	(100.0 L)
Fuel Consumption (65% of Full Load)	2.6 gal/hr	(10.0 L/hr)
Hydraulic Reservoir Capacity	12.0 gal	(45.0 L)
Front Axle Lubrication	1.59 qt	(6.0 L)
Rear Axle Lubrication	1.53 qt	(5.8 L)



Deluxe Light Package



Z-Bar Linkage



Center Frame Oscillation



Hydraulic Oil Sight Gauge

ATTACHMENTS

Takeuchi now offers attachments for all of your Takeuchi equipment. See your authorized Takeuchi dealer for addition information and attachment options.



4-in-1 Bucket



Low Profile Buckets



Grapple -Brush



Grapple - Scrap

TW65 Series 2 Wheel Loader

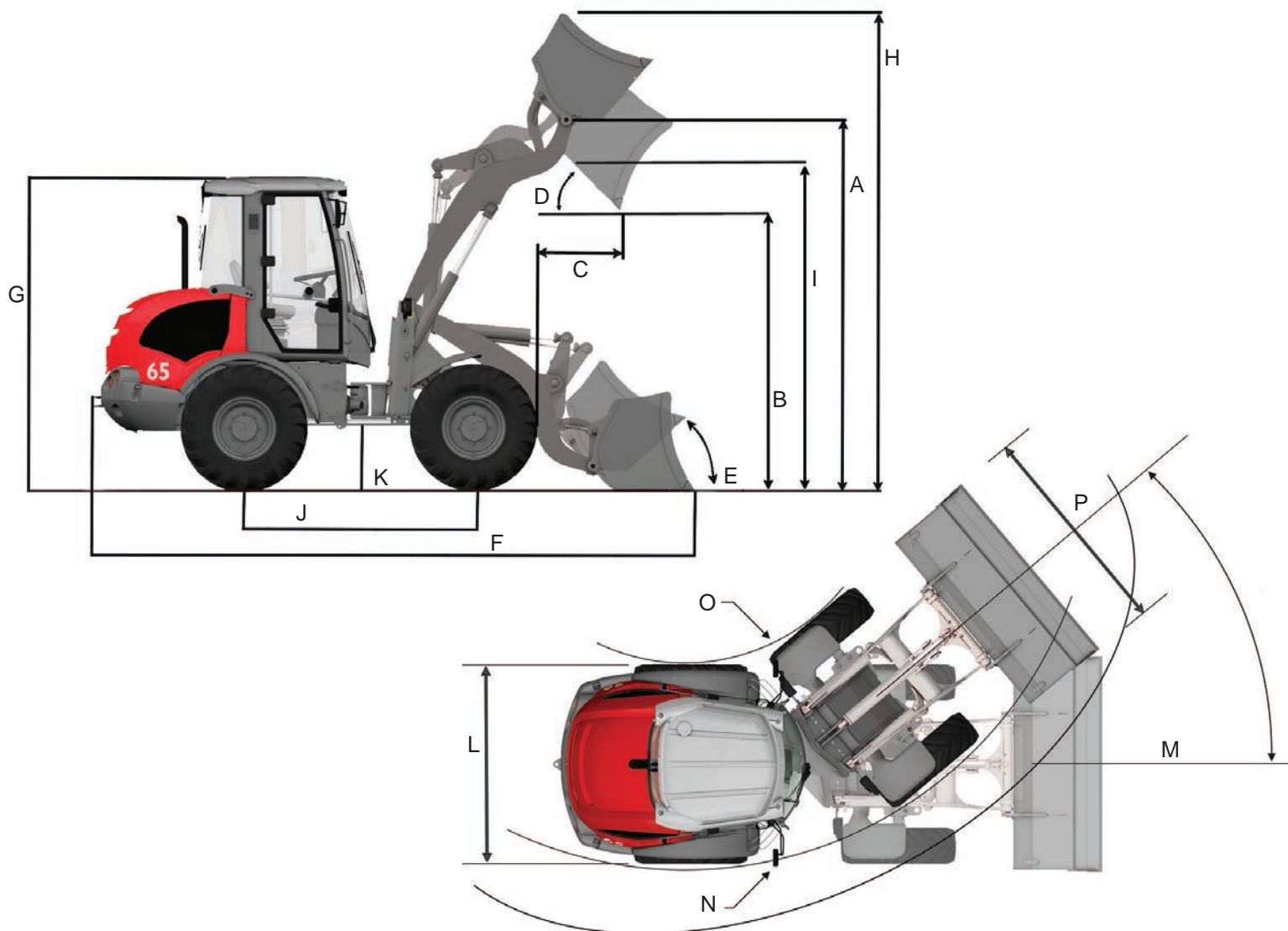

MACHINE DIMENSIONS

A	Max. Lift Height to Bucket Pin	10 ft 4.6 in	(3,165 mm)
B	Dump Height Fully Raised	8 ft 1.0 in	(2,465 mm)
C	Max. Reach Fully Raised	2 ft 0.0 in	(625 mm)
D	Dump Angle	45°	
E	Rollback Angle	48°	
F	Overall Length with Bucket	17 ft 3.0 in	(5,250 mm)
G	Overall Height	8 ft 10.0 in	(2,689 mm)
H	Overall Operating Height	13 ft 0.0 in	(3,960 mm)
I	Bucket Clearance Height	9 ft 2.0 in	(2,800 mm)
J	Wheel Base	6 ft 6.7 in	(2,000 mm)
K	Ground Clearance	1 ft 5.7 in	(450 mm)
L	Overall Width without Bucket	6 ft 1.5 in	(1,870 mm)
M	Turning Radius at Bucket Edge	13 ft 8.0 in	(4,164 mm)
N	Outside Turning Radius	12 ft 2.0 in	(3,715 mm)
O	Inside Turning Radius	5 ft 11.0 in	(1,817 mm)
P	Recommended Bucket Width	71 in	(1,803 mm)



2 YEAR
2,000 HOUR
FULL MACHINE
WARRANTY

© 2017 Takeuchi Manufacturing (U.S.), Ltd. All Rights Reserved. Printed in the U.S.A. In accordance with our established policy of continued improvement, specifications and features are subject to change without notice. Pictures may show options other than standard equipment.
FORM: TW65 Series 2 Wheel Loader Spec Sheet - Mar. 2017

TAKEUCHI
From World First to World Leader